

Automatic ad-lib piglet feeding system



RescueCare cup system

- Simple and easy to use
- Maximum feed intake before weaning
- Wean more and heavier piglets
- Increased sow performance
- A closed system with continuous supply of warm milk
- Proven concept, already 10 years on the market

VDL Agrotech



Automatic ad-lib piglet feeding system

Neopigg™ RescueCare Cup system

Cup

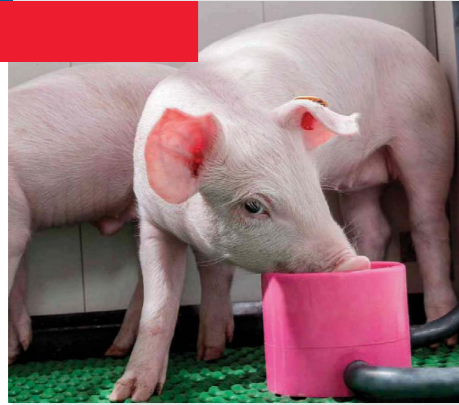

The modern pig industry faces challenges every day. The number of live born piglets grows every day while the quantity of milk produced by the sow remains at the same level. Therefore providing liquid piglet feed in the farrowing pen is getting more and more important. With the RescueCare system piglets have ad-lib access to fresh liquid feed starting from day one. With the unique drinking-cup the piglets can control by themselves the daily feed intake. Research shows that the system gives an increase of 30% in the total delivered kilograms of piglets per sow per year. Also it is labour saving for approximately 5-10%.

Feed Kitchen



Feed Kitchen

The feed kitchen is the heart of the installation. The liquid pig feed (milk or pre-starter) is prepared in a mixer-tank. Instead of distributing the feed manually, this system pumps 24/7 automatically it into all compartments. The piglets control themselves the feed intake by their individual need. The system is compact, modular plug & play and easy to use. Farms without a special space for a feed kitchen can install the system also in the central corridor. Important is that there will be sufficient hot water available.

Nipple



Drinking cup with unique nipple

The RescueCare cup has an attractive colour that will be recognised by the piglet from day one. The piglets are eager to learn and know very quickly how to operate the nipple. The patented nipple regulates the feed supply automatically. When the cup is filled up, the nipple and feed supply will be blocked to prevent flooding. This avoids feed spillage and keeps the feed inside the system fresh. Depending on the preferences of the farmer and the lay-out of the farrowing pen the cup can be placed in different places.

Closed system



Mixer tank & control

Mixer tank

The mixer tank is made of food graded plastic and a stainless steel support frame. Thanks to the special production process there are no gaps or seams in the tank surface, which makes it very fast and easy to clean. The powerful mixer motor is mounted at an angle on the bottom of the tank. The advantages of this construction are:

- Safe & easily accessible for cleaning/product preparation
- Homogeneous product within 2 minutes mixing (full tank)
- Small amount of residue feed
- No sediment because of periodic mixing of the motor

Two available models: 200 litre or 400 litre capacity. The optimal capacity depends on the number of cups/decks per tank and how often fresh feed will be prepared. The tanks are pre-assembled and plug & play delivered.

Available options: temperature sensor, transparent cover, automatic water counter, automatic water dosing when tank is empty.

Control

There are two types of controllers available: Basic and Touch, both types are characterized by:

- User friendly functional design
- Plug & Play
- Automatic and manual control of mixer and pump
- All electrical components are compatible (tank/pump/water dosing)

The Touch-controller is provided with an intuitive colour touch-screen. The operation is herewith clear and easy. The operator can easily select the language.

Controller RescueSystem Basic



Controller RescueSystem Touch



Easy language selection

ЯЗЫК	
Deutsch	English
Nederlands	Polski
русский	français
italiano	dansk
한국어	Español



Pumps & cup position

Pumps

Special pumps have been selected for the RescueCare system with exact flow characteristics and chemical resistance against milk replacer, liquid pre-starter and cleaning products. Two types of pumps are available, electric and pneumatic. For short circuits till approx. 200 meter electrical pumps can be used. The flow can be easily adjusted by use of a frequency converter.

For longer circuits pneumatically membrane pumps will be used. The pumps can easily be installed in a serial set-up to cover longer distances. Another advantage of a pneumatic pump is that the structure of the feed will be not damaged.

Depending on the preferences of the farmer and the layout of the farrowing house the best suitable pumps selected. The

RescueCare system offers a custom made solution for all types of farms consisting of different modules.

Position cup

Not every farrowing pen is identical; often the experience and the vision of the farmer are integrated in the design. For positioning the RescueCare cup there are several options

but this is mainly depending on the position of the closed floor, heating plates or canopy:

- Cup in the front or rear of the farrowing pen
- Cup left or right side of the farrowing pen
- Hoses above or beneath the slats



Electrical pump

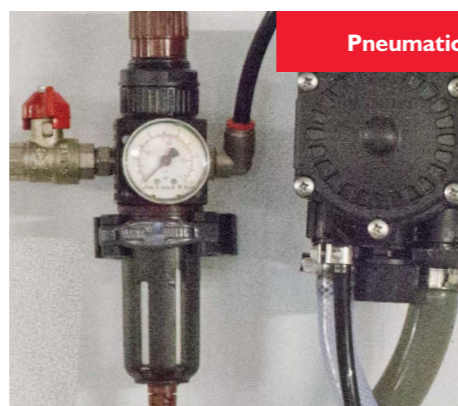

Pneumatic pump



Farrowing pen

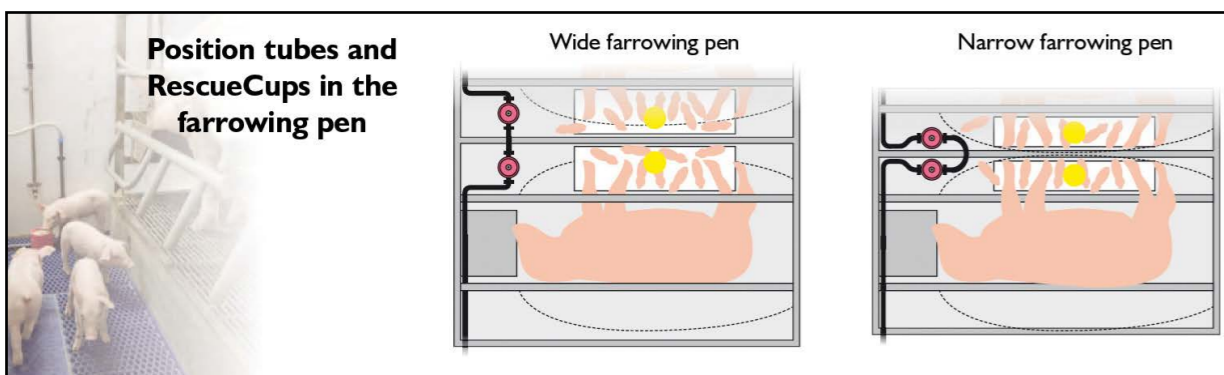

Management & feeding scheme

Management

The RescueCare system is an extreme user friendly semi-automatic feeding system. The Basic-controller is easy to operate and suitable

for 1 mixer tank. The Touch-controller is suitable for 2 mixer tanks and has some additional features. For example: temperature monitoring, event-logger and mixture schemes per feed type.

The Touch-controller stores data in a so called event-log. Every manual operation or activity will be registered together with date, time and temperature etc. This data can be copied as and Excel file on a USB-stick and can be analysed on your office computer.

Feeding scheme

The RescueCare system is suitable for milk replacer and liquid pre-starter with a mixing ratio from 150 - 250 gr/litre water. From day 2 until just before weaning the piglets will be fed with the cups. The advice is to give the piglet's additional weaner diet from day 7-12 to

	0	1	2	3	4	5	6	7	8	9	10	11	12	13	14	15	16	17	18	19	20	21	22	23	24	25	26	27	28
Milk replacer																													
Liquid pre-starter																													
Weaner diet																													

Please contact your feed supplier for the ideal scheme for your farm.

Schematic overview RescueCare System

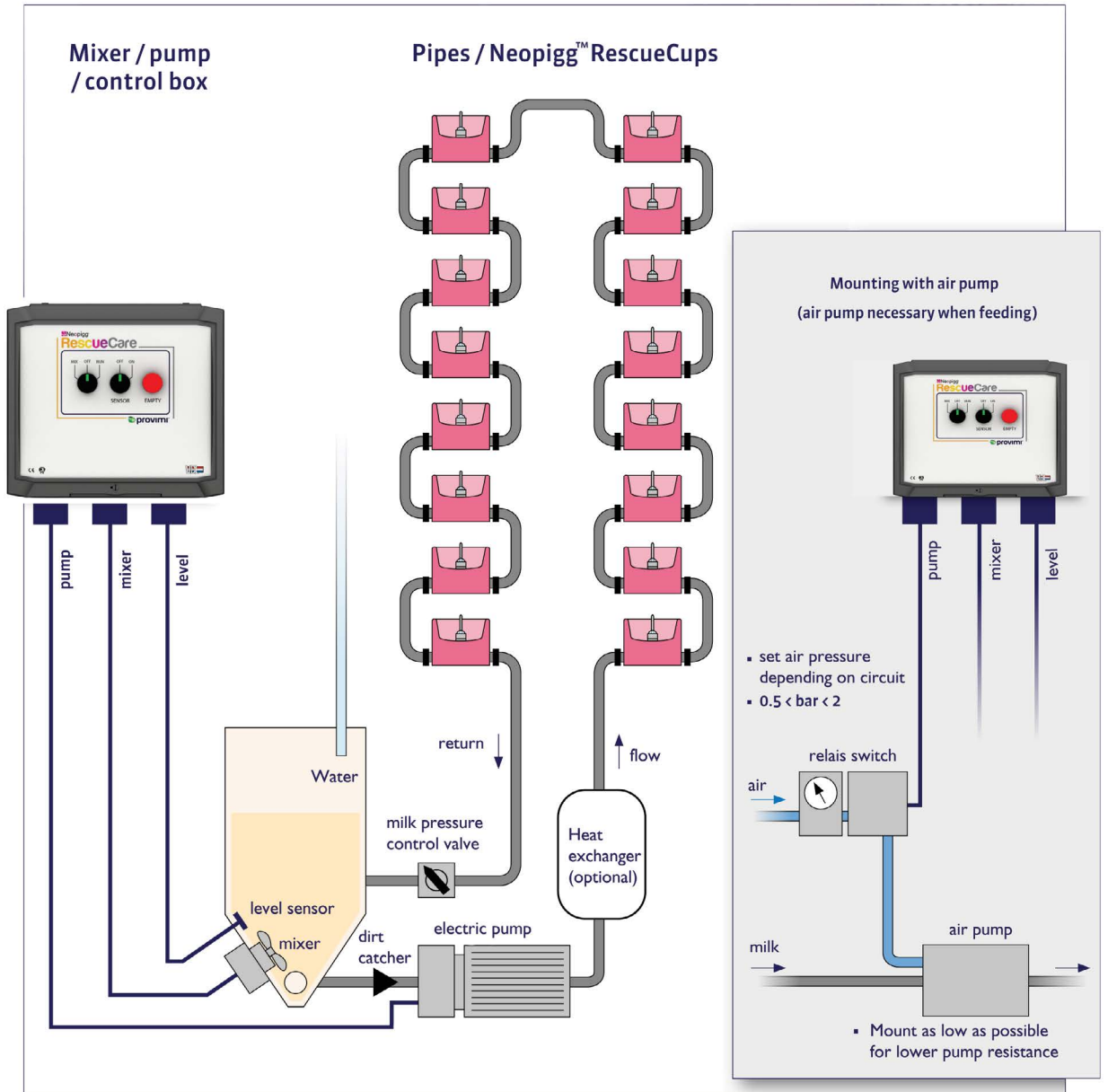

Dealer

VDL Agrotech 

P.O. Box 8822, 5605 LV Eindhoven, T: +31(0)40 29 25 500
 www.vdlagrotech.com, info@vdlagrotech.nl, F: +31 (0)40 29 25 501

V2018xxx